

For commercial use

Modbus interface

Model name:

BMS-IFMB1280U-E

BMS-IFMB1280U-TR

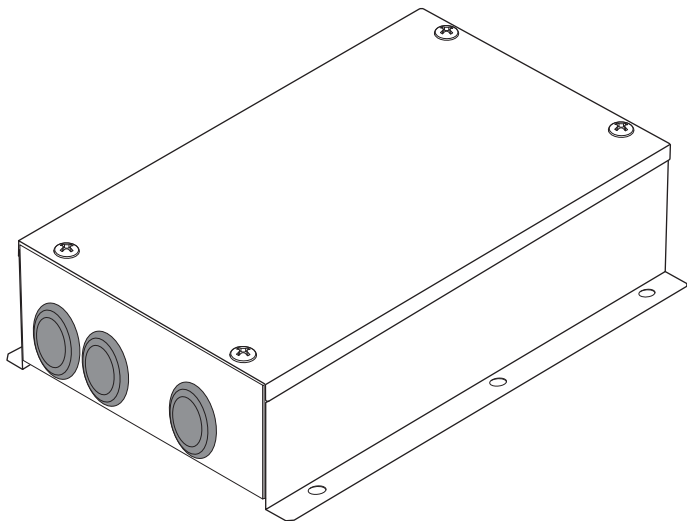

Multilingual installation manuals



[Български] Ръководство за монтаж Изтегляне / [Česky] Stažení montážní příručky / [Dansk] Installationsvejledning, Download / [Deutsch] Installationshandbuch Herunterladen / [Ελληνικά] Λήψη Εγχειριδίου εγκατάστασης / [English] Installation manual Download / [Español] Descarga del Manual de instalación / [Eesti] Paigaldusjuhendi allalaadimine / [Suomi] Asennusohjeiden lataaminen / [Français] Manuel d'installation Téléchargement / [Hrvatski] Priručnik za instalaciju Preuzimanje / [Magyar] Telepítési kézikönyv Letöltés / [Italiano] Manuale di installazione Scaricamento / [Latviešu] Uzstādīšanas rokasgrāmata Lejupielādēt / [Norsk] Installasjonsveiledning Last ned / [Nederlands] Installatiehandleiding downloaden / [Polski] Pobieranie Instrukcji instalacyjnej / [Português] Transferência do manual de instalação / [Română] Manual de instalare Descărcare / [Русский] Руководство по установке Скачать / [Slovensky] Montážna príručka Stiahnutie / [Slovenščina] Prenos navodil za montažo / [Svenska] Installationshandbok Nedladdning / [Türkçe] Kurulum kılavuzu İndirme / [中文] 安装手册下载

<https://www.toshiba-carrier.co.jp/global/manual/bms-ifmb1280u.htm>

- Thank you very much for purchasing this TOSHIBA Modbus interface.
- Please read this manual carefully beforehand for proper installation of the Modbus interface.



“AEEE Yönetmeliğine Uygundur.”

Contents





1	Precautions for safety	2
2	Introduction	3
3	Before installation	4
4	Installation	4
5	Connection of power cables / earth wires / communication cables	5
6	Setting	13
7	Test run check	17

1 Precautions for safety



- Read these “Precautions for Safety” carefully before installation.
- The precautions described below include important items regarding safety. Observe them without fail. Understand the following details (indications and symbols) before reading the body text, and follow the instructions.
- After the installation work has been completed, perform a test run to check for any problems. Explain how to use and maintain the unit to the customer.
- Ask customer to keep this Manual at accessible place for future reference.

Indication	Meaning of Indication
 WARNING	Text set off in this manner indicates that failure to adhere to the directions in the warning could result in serious bodily harm (*1) or loss of life if the product is handled improperly.
 CAUTION	Text set off in this manner indicates that failure to adhere to the directions in the caution could result in serious bodily injury (*2) or damage (*3) to property if the product is handled improperly.



- *1: Serious bodily harm indicates loss of eyesight, injury, burns, electric shock, bone fracture, poisoning, and other injuries which leave aftereffect and require hospitalization or long-term treatment as an outpatient.
- *2: Bodily injury indicates injury, burns, electric shock, and other injuries which do not require hospitalization or long-term treatment as an outpatient.
- *3: Damage to property indicates damage extending to buildings, household effects, domestic livestock, and pets.

Symbols	Meaning of Symbols
	“  ” Indicates prohibited items. The actual contents of the prohibition are indicated by a picture or text placed inside or next to the graphic symbol.
	“  ” Indicates compulsory (mandatory) items. The actual contents of the obligation indicated by a picture or text placed inside or next to the graphic symbol.

WARNING

	<ul style="list-style-type: none"> • Ask an authorized dealer or qualified installation professional to install or reinstall this unit. Inappropriate installation may result in electric shock or fire. • Electrical work must be performed by a qualified electrician in accordance with this installation manual. The work must satisfy all local, national and international regulations. Inappropriate work may result in electric shock or fire. • Be sure to turn off all main power supply switches before starting any electrical work. Failure to do so may result in electric shock.
	<ul style="list-style-type: none"> • Do not modify the unit. A fire or an electric shock may occur.

CAUTION

	<ul style="list-style-type: none"> • Do not install this unit where flammable gas may leak. If gas leaks and accumulates around the unit, it may cause a fire.
	<ul style="list-style-type: none"> • Perform wiring correctly in accordance with specified the current capacity. Failure to do so may result in short-circuiting, overheating or fire. • Use predefined cable and connect them certainly. Keep the connecting terminal free from external force. It may cause an exothermic or a fire.

2 Introduction

■ Applications / Functions / Specifications

Applications

- The Modbus interface is used to connect air conditioners “with TU2C-LINK Uh Line (hereinafter, referred to as Uh Line) installed” and TCB-IFCG1TLE to Modbus* system.

Functions

- The Modbus interface converts signals between Uh Line and Modbus Master.

Specifications

Power supply	220 - 240 VAC, 50/60 Hz
Power consumption	3 W
Operating temperature / humidity	0 to 40 °C, 10 to 90 % RH (no condensation)
Storage temperature	-20 to +60 °C
Chassis material	Galvanized sheet metal 0.8 t (no coating)
Dimensions	66 (H) x 170 (W) x 200 (D) mm
Mass	1.1 kg

* Note) “Modbus” is a registered trade mark of Schneider Electric SA.

■ External view

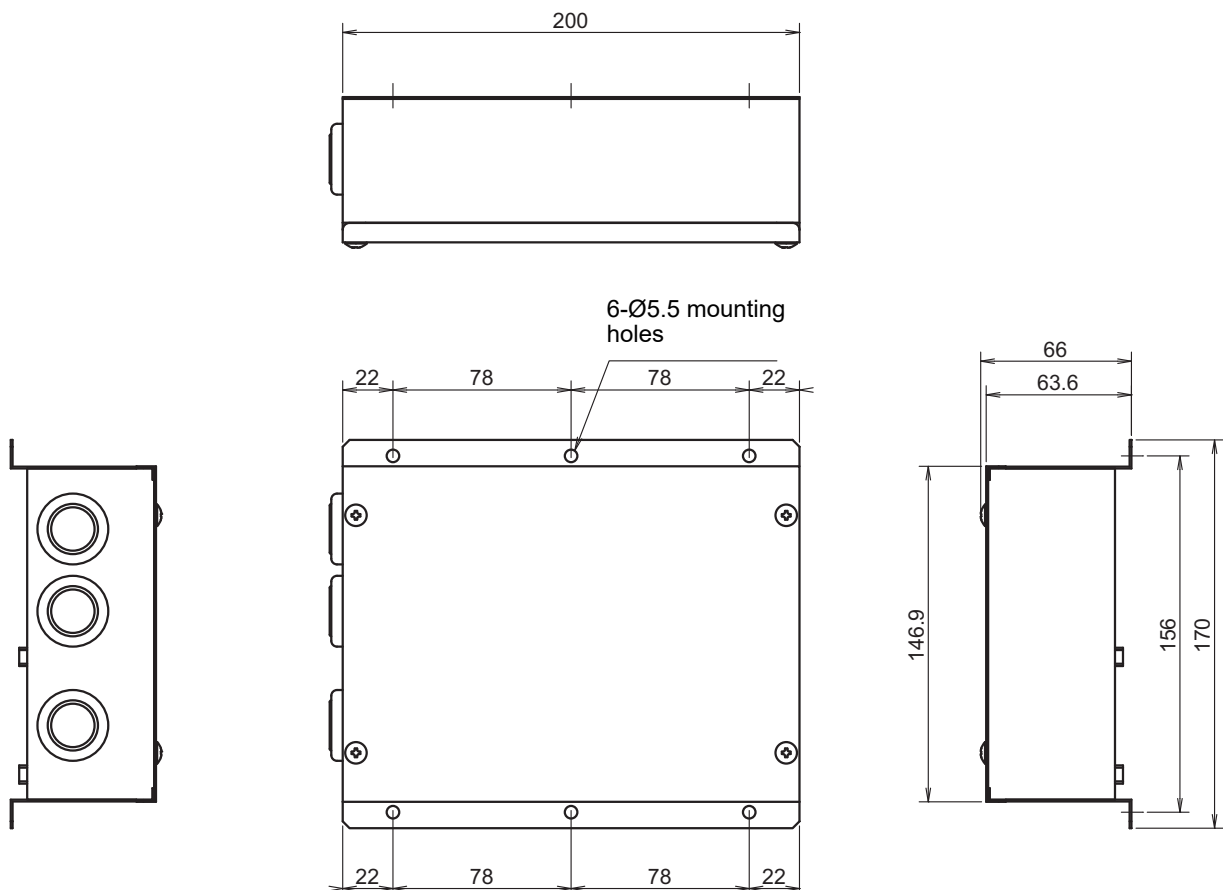

3 Before installation

Check the following package contents.

No.	Item	Quantity	Remarks
1	Modbus interface	1	
2	Installation Manual	1	
3	Screw	4	M4 x 12 mm tapping screws
4	Cable clamp	1	

Use the following wiring materials to connect the communication cables and power cables. (locally procured)

No.	Line	Description	
1	For Uh Line	Type	Refer to "Design of Control Wiring"(P.7 to P.11).
		Wire size	
		Length	
2	For RS-485	Type	2-core shielded wires
		Wire size	1.25 mm ² , 500 m max.
		Length	(total length)
3	For power	Type	H07 RN-F or 245IEC66
		Wire size	0.75 mm ² , 50 m max.

4 Installation

■ Modbus interface installation method and orientation

There are five installation methods for this Modbus interface as shown below: surface mount and wall mounts. Use the attached screws.

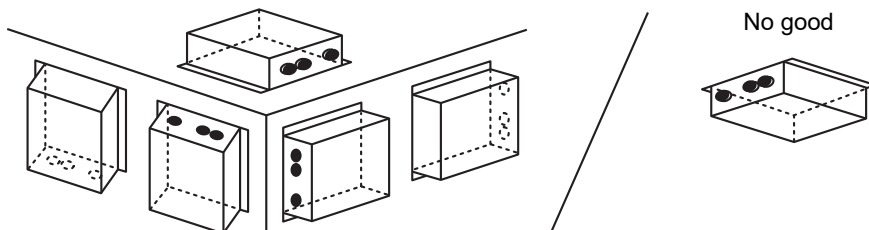

REQUIREMENT

Do not install the unit in any of the following places.

- Humid or wet place
- Dusty place
- Place exposed to direct sunlight
- Place where there is a TV set or radio within one meter
- Place exposed to rain (outdoors, under eaves, etc.)

■ Installation space and maintenance space

A side space for connecting through cable inlets and an upper space for maintenance must be reserved before installation.

The other sides can be adjacent to surrounding objects.

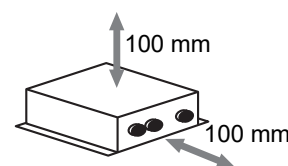

5 Connection of power cables / earth wires / communication cables

CAUTION

- The RS-485 communication cables have polarity. Connect A(+) to A(+), and B(-) to B(-). If connected with incorrect polarity, the unit will not work.
- The Uh Line communication cable have no polarity.

Connect power cables, earth wires, and communications cables to the specified terminals on the terminal block.

Length of stripped RS-485 communication cable (not shielded wire ends)

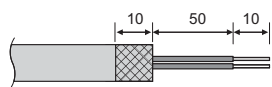

Clamping RS-485 communication cable (address 1)

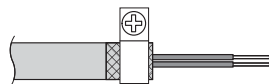

The RS-485 communication cable must be earthed on address 1 (Modbus interface address SW=1) Modbus interface. Fix the shielded wire of RS-485 communication cable with metal cable clamp and screw it to the chassis to earth it.

Length of stripped RS-485 (Shielded wire ends) and Uh Line communication cable

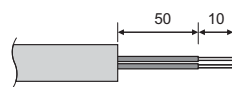

Clamping communication cable

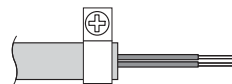

Do not connect the shield wire to the earth. It should be open and insulated.

Length of stripped power cable

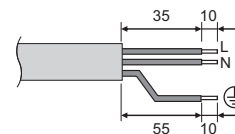

The shielded wires must be crimped with closed end connectors on interfaces with address of other than 1 and not shielded wire ends.

Termination resistance setting

- TU2C-LINK / TCC-LINK termination resistance setting<For TCC-LINK>
 Leave just 1 line of the termination resistance in the interface board of the outdoor unit (centre unit) ON, and turn all the others OFF. (Refer to the wiring diagram attached to the outdoor unit for the position of SW.)
 <For TU2C-LINK>
 For the central control wiring (Uh line), set the termination resistance that is farthest away on the wiring between this central controller and the other unit (VRF light commercial, air to air heat exchanger, general purpose control interface, air to water heat pump) to ON.

Refer to the manual of each model for the termination resistance setting method.

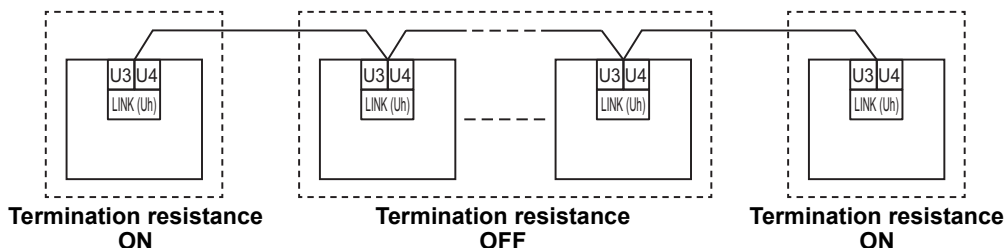

Shield grounding process

- Central control wiring shielded wireWhen using the central remote controller with one unit, open the shielded wire of the central control wiring and perform insulation processing.
 When using the central remote controller with multiple units, connect the shield of the central control wiring to the closed end and open the shield at the final end of the central remote controller to perform insulation processing. Perform the central control wiring shield grounding on the air conditioner side.

REQUIREMENT

- Be sure to install a circuit breaker or all-pole isolating switch (with a contact breaking distance of at least 3 mm) on the primary side of the power supply.
- Fasten the screws to the terminal block with torque of 0.5 N•m.

■ Design of Control Wiring

Communication method and model name

The TU2C-LINK model (U series) can be used together with previous models (other than U series).

For details of the model and communication method, see the following table.

Communication method	TU2C-LINK (U series)	TCC-LINK (other than U series)
Outdoor unit	MMY-MUP*** ↑ _____ U series model	Other than on the left (MMY-MAP***, MCY-MAP***, etc.)
Indoor unit	MM*-UP*** ↑ _____ U series model	Other than on the left (MM*-AP***, etc.)
Wired remote controller	RBC-AMSU** ↑ _____ U series model	Other than on the left
Wireless remote controller receiver	RBC-AXRU** ↑ _____ U series model TCB-AXRU** ↑ _____ U series model	Other than on the left
Central control device	***-***U** ↑ _____ U series model	Other than on the left

When the connected outdoor unit is Super Multi u series (U series)

Follow the wiring specifications in the table below even when there is a mix of U series and non-U series in the connected indoor units or remote controllers.

Wiring specifications

Item	Communication line
	Central control wiring (Uh line)
Wire diameter	1.0 to 1.5 mm ² (up to 1000 m)
	2.0 mm ² (up to 2000 m)
Wire type	2-core, non-polar
Wire types that can be used	Shielded wire

REQUIREMENT

When wiring the control wiring between indoor and outdoor units (Uv line)/control wiring between outdoor units (Uc line) and the central control wiring (Uh line), use the same wire type and diameter for each line. Using a mixture of different wire types and diameters may cause a communication error.

System diagram

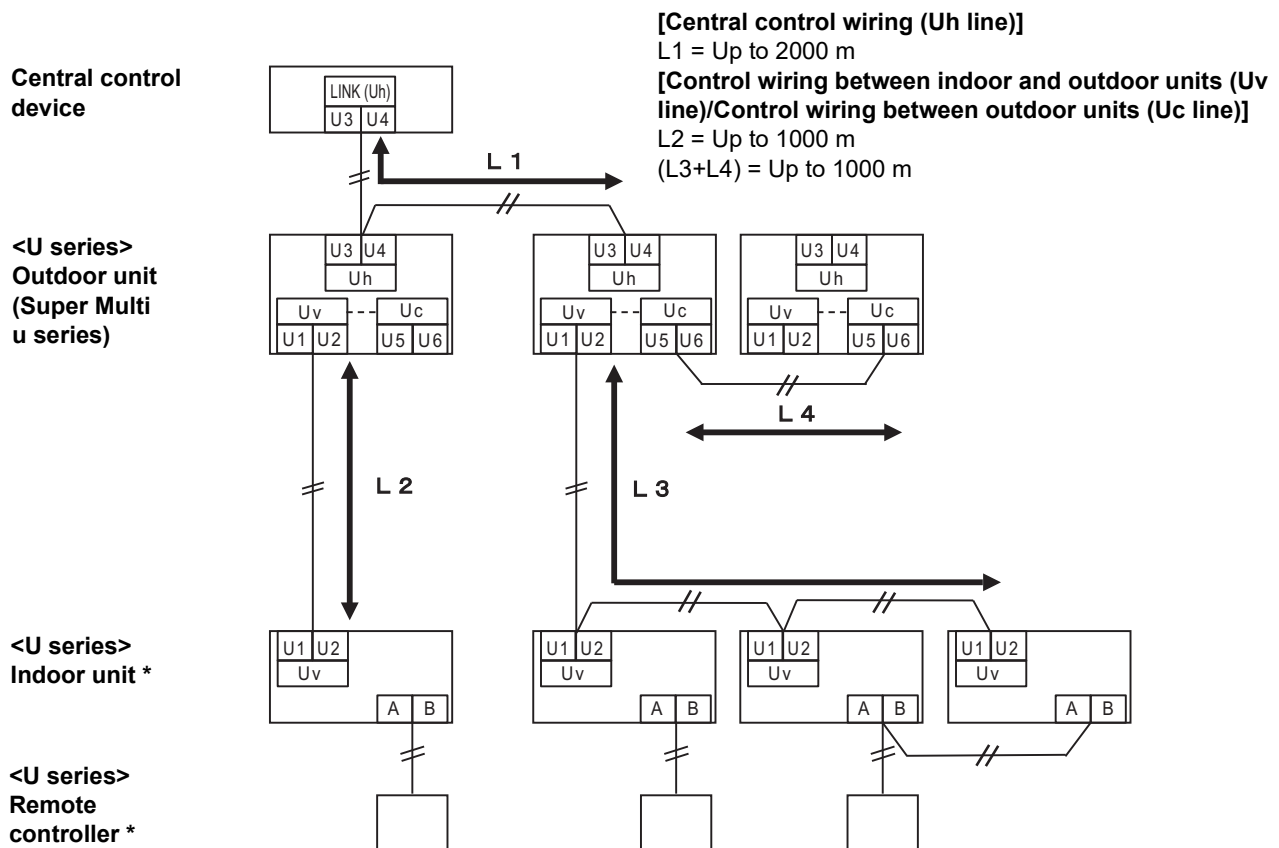

* The wiring specifications in the system diagram above are the same even when the indoor unit or remote controller are other than the U series.

When the connected outdoor units are other than Super Multi u series (U series)

Wiring specifications

Item	Communication line
	Control wiring between indoor and outdoor units and central control wiring
Wire diameter	1.25 mm ² (up to 1000 m)
	2.0 mm ² (up to 2000 m)
Wire type	2-core, non-polar
Wire types that can be used	Shielded wire

REQUIREMENT

When wiring the control wiring between indoor and outdoor units/central control wiring and the control wiring between outdoor units, use the same wire type and diameter for each line.

Using a mixture of different wire types and diameters may cause a communication error.

System diagram

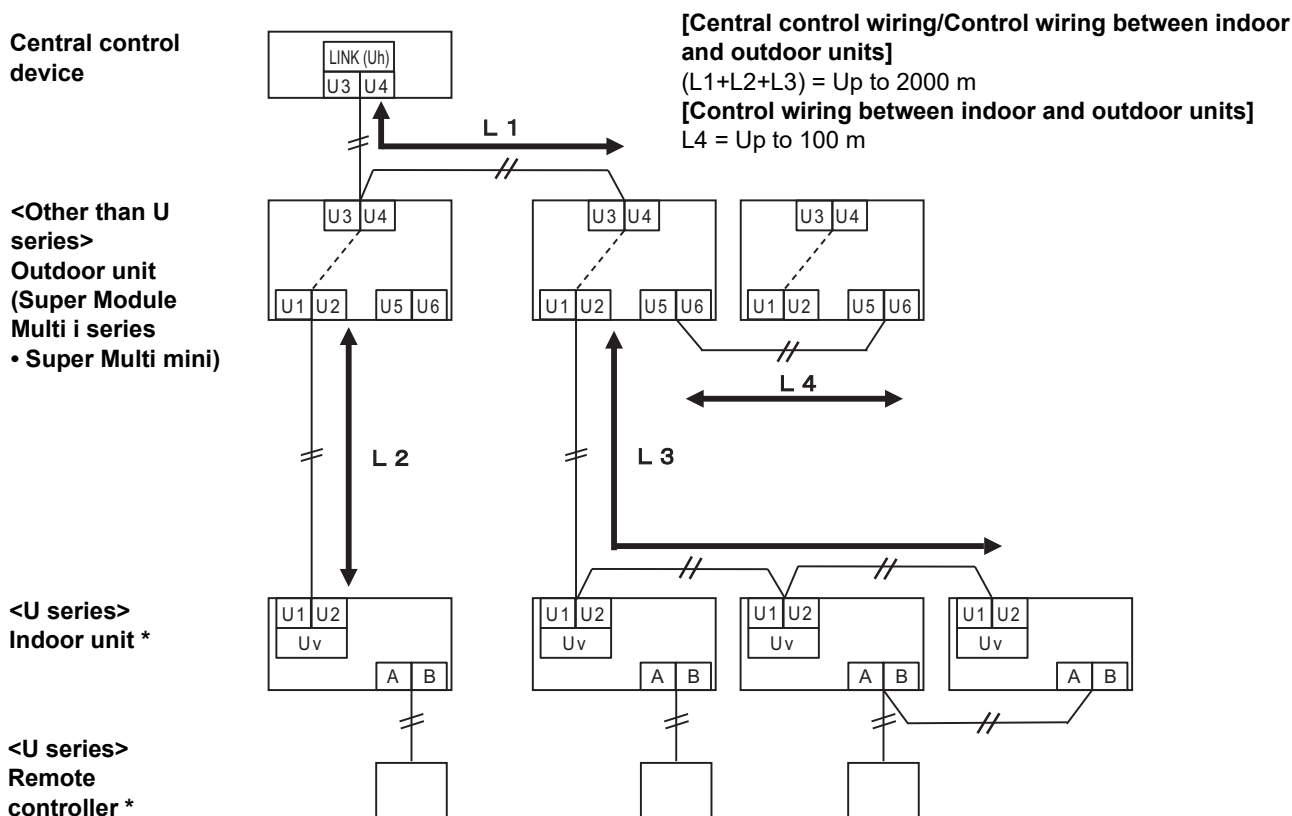

* The wiring specifications in the system diagram above are the same even when the indoor unit or remote controller are other than the U series.

When connecting to a previous model light commercial, air to air heat exchanger, air to water heat pump, or general purpose equipment control interface

Follow the wiring specifications in the table below even when there is a mix of U series and non-U series in the connected indoor units or remote controllers.

Wiring specifications

Item	Communication line
	Central control wiring (Uh line)
Wire diameter	1.25 mm ² (up to 1000 m)
	2.0 mm ² (up to 2000 m)
Wire type	2-core, non-polar
Wire types that can be used	Shielded wire

REQUIREMENT

When wiring the control wiring between indoor and outdoor units (Uv line)/control wiring between outdoor units (Uc line) and the central control wiring (Uh line), use the same wire type and diameter for each line.
Using a mixture of different wire types and diameters may cause a communication error.

System diagram

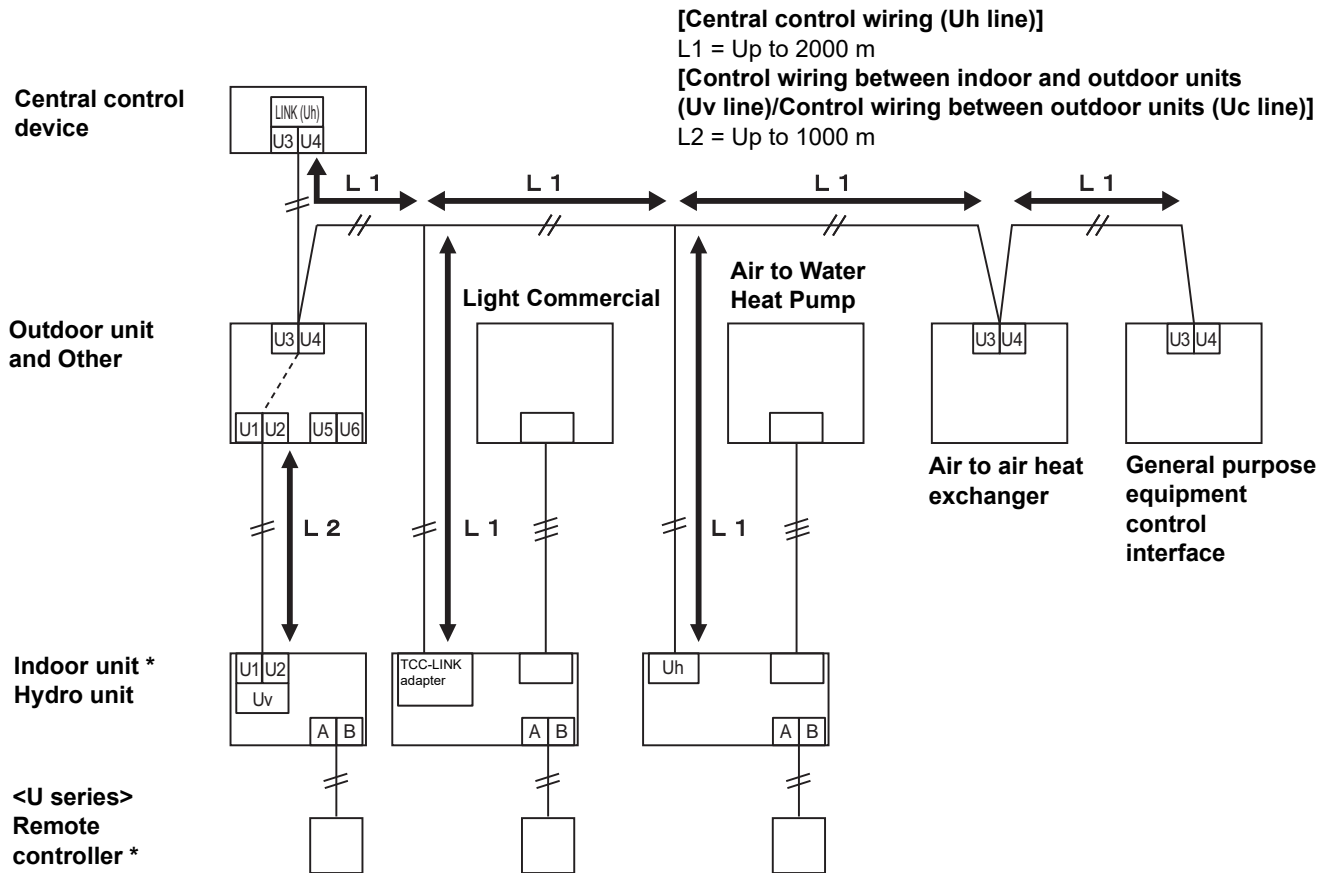

* The wiring specifications in the system diagram above are the same even when the indoor unit or remote controller are other than the U series.

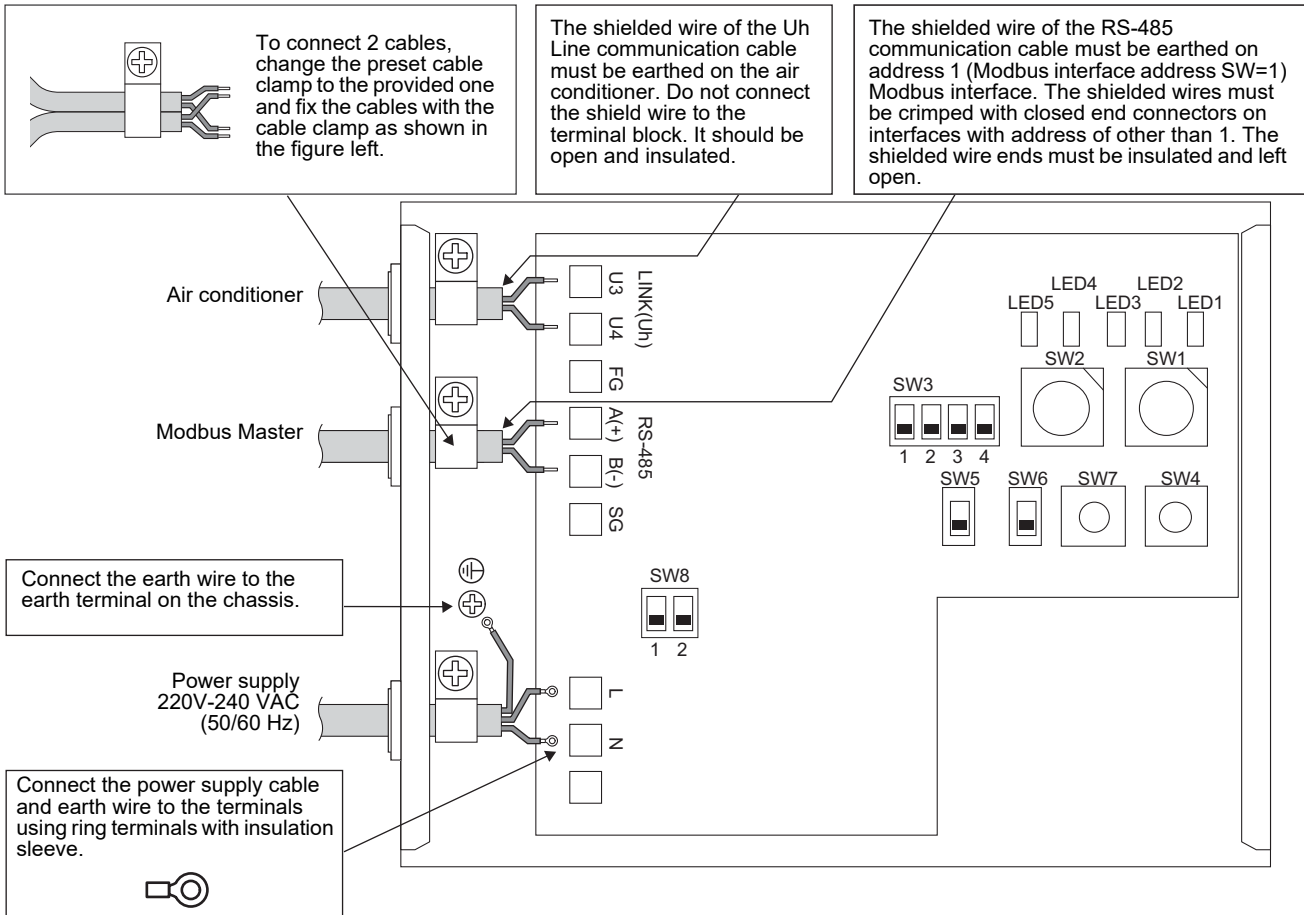

REQUIREMENT

Disconnect the appliance from the main power supply.

This appliance must be connected to the main power supply by a circuit breaker or switch with a contact separation of at least 3 mm.

Fasten the screws to the terminal with torque of 0.5 Nm.

■ Wiring connection

The following describes a connection example when two or more Modbus interface units are used.

Termination resistance setting (See “6 Setting” for the setting method.)

- Set the RS-485 termination resistance to “120 ohm” for address1 (Modbus interface address SW1=1) Modbus interface unit, and set to “open” for other units.
- Set the Uh Line Termination resistance.
Refer to "Termination resistance setting"(P.6)

Shield earthing

- The shielded wire of the RS-485 communication cable must be earthed on address 1 (Modbus interface address SW=1) Modbus interface. Fix the shielded wire of RS-485 communication cable with metal cable clamp and screw it to the chassis to earth it. The shielded wires must be crimped with closed end connectors on interfaces with address of other than 1. The shielded wire ends must be insulated and left open.
- Do not connect the shield wire to the terminal block. It should be open and insulated. The shielded wire of the Uh Line communication cable must be earthed on the air conditioner.

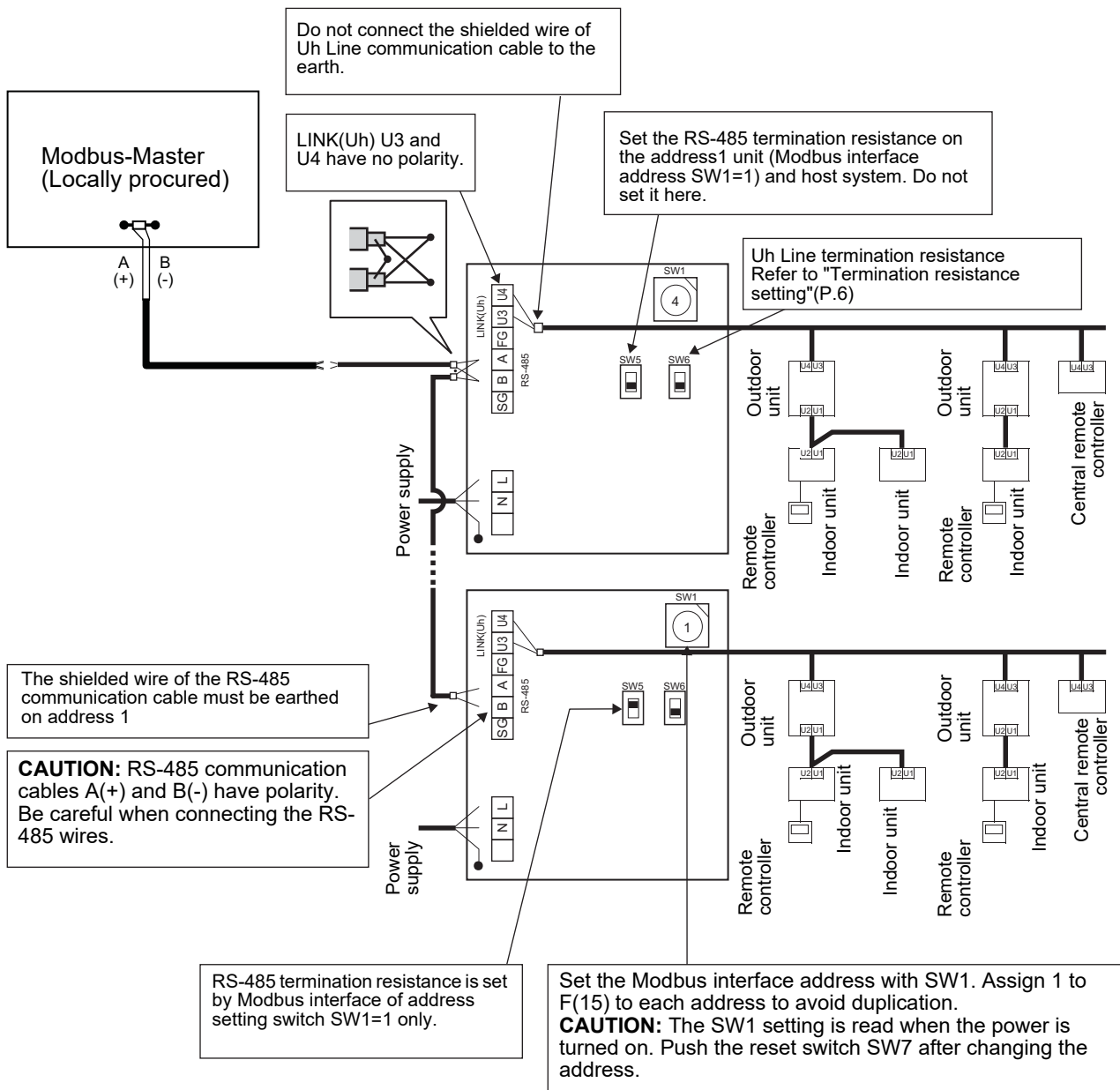

6 Setting

The following settings are necessary to use Modbus interface.

- SW1 Sets the Modbus slave addresses of the Modbus interface.
A single Modbus interface uses three Modbus slave addresses.
(One address for the current interface and two addresses for potential interfaces.)
When two or more Modbus interfaces are used for a single line RS-485 bus, set the addresses as indicated in the table below.
Assign address numbers in ascending order, from smallest to largest.

Modbus interface	Address
No.1	1
No.2	4
No.3	7
No.4	10
No.5	13

CAUTION

- For the Modbus interface whose address SW1=1, perform termination resistance setting.
- When the SW1 setting has been changed, press the reset switch SW7. The new address setting is read.
- When the setting of bit3 and bit4 of SW3 has been changed, press the reset switch SW7. The new set value is read.

- SW2 Test switch Not used during operation. Set these switches to zero (0) or "all OFF".
- SW3 Test switch
 - Bit1: Central controller ID setting mode switch
 - Bit2: Switches the LED5 display for test runs.
 - Bit3, 4: RS-485 baud rate setting (9600/19200/38400) bps.
- SW4 Test switch Not used during operation.
- SW5 RS-485 termination resistance select switch
Set "120 ohm" only when the Modbus interface address SW=1, and set "open" for other Modbus interfaces.
- SW6 Uh Line termination resistance select switch
Refer to "Termination resistance setting"(P.6)
- SW7 Reset switch
When performing an address setting with SW1, push this reset switch after the address setting to read the set value.
- SW8 Test switch (Not used during operation. All OFF usually)

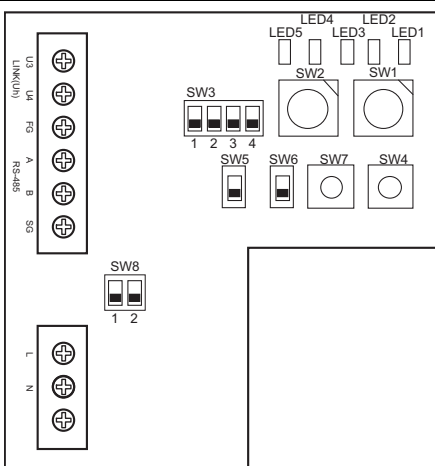

SW1	Modbus interface address set switch					
	1-F	Modbus interface address				
	0	Not used				
SW2	Test switch (0 usually)					
SW3	Bit1: Uh Line communication setting mode switch. OFF: Normal circumstance; ON: Central controller ID setting mode					
	Bit2: Switches the LED5 display for test runs. OFF RS-485 communication status indicator. ON Uh Line communication status indicator.					
	Bit3, 4: RS-485 baud rate setting (9600/19200/38400) bps. 3 OFF, 4 OFF 9600 bps, 3 ON, 4 OFF 19200 bps, 3 OFF, 4 ON 38400 bps, 3 ON, 4 ON 19200 bps.					
	SW4 Test switch					
SW5	RS-485 termination resistance select switch	<table border="0"> <tr> <td></td> <td>120 ohm</td> <td></td> <td>Open</td> </tr> </table>		120 ohm		Open
	120 ohm		Open			
SW6	Uh Line termination resistance select switch	<table border="0"> <tr> <td></td> <td>100 ohm</td> <td></td> <td>Open</td> </tr> </table>		100 ohm		Open
	100 ohm		Open			
SW7	Reset switch					
SW8	Test switch (all OFF usually)					
LED1	Power indicator					
LED2	RS-485 communication status indicator					
LED3	Uh Line communication status indicator					
LED4	Uh Line communication error indicator					
LED5	Test indicator					

REQUIREMENT

- **RS-485 termination resistance select switch SW5.**
Set "120 ohm" only when the Modbus interface address SW=1, and set "open" for other Modbus interfaces.
- **The Uh Line termination resistance is set on the air conditioner side. Set SW6 to "open".**

■ Central controller ID setting mode

The central controller ID setting mode changes the central controller ID of the Modbus interface. (central controller ID at the time of factory shipping is central controller ID 20.)

The central controller ID number indicates the Uh Line address and communication priority for the Uh Line compatible central control device.

Change the central controller ID in the following cases.

- If using Modbus interface with a central control device not compatible with Uh Line, set the central controller ID as “old controller.”

(1) Transition to central controller ID setting mode

- If setting the Modbus slave address with SW1, make a note of the SW1 value before performing central controller ID setting operations.
- Turn on bit1 of SW3.

(2) Verification of central controller ID

- If SW1 is set to 0, central controller ID is displayed by LED2 to LED5.

○=ON, ●=OFF

Central controller ID	LED5	LED4	LED3	LED2
Central controller ID7	●	●	●	○
Central controller ID8	●	●	○	●
Central controller ID9	●	●	○	○
Central controller ID10	●	○	●	●
Central controller ID11	●	○	●	○
Central controller ID12	●	○	○	●
Central controller ID13	●	○	○	○
Central controller ID14	○	●	●	●
Central controller ID15	○	●	●	○
Central controller ID16	○	●	○	●
Central controller ID17	○	●	○	○
Central controller ID18	○	○	●	●
Central controller ID19	○	○	●	○
Central controller ID20 (initial value)	○	○	○	●
Old controller	○	○	○	○

(3) Change of central controller ID

- Change SW1 to 1-F and press SW4.
- If using Modbus interface with a central control device not compatible with Uh Line, set as “old controller.”

Central controller ID	SW1
Central controller ID7	1
Central controller ID8	2
Central controller ID9	3
Central controller ID10	4
Central controller ID11	5
Central controller ID12	6
Central controller ID13	7
Central controller ID14	8
Central controller ID15	9
Central controller ID16	A
Central controller ID17	B
Central controller ID18	C
Central controller ID19	D
Central controller ID20 (initial value)	E
Old controller	F

NOTE

Because the Uh Line compatible central control device uses high-order central controller ID, setting of central controller ID1 to ID6 cannot be done with Modbus interface.

(4) Conclusion of central controller ID setting mode

- Turn off bit1 of SW3.
- Return the SW1 value to that of the Modbus slave address.

IMPORTANT

Immediately after the power is turned on for the Modbus interface, the SW1 value is the Modbus slave address. When the power is turned on, if the SW1 value is that of the central controller ID or is 0, the Modbus interface will not operate properly.

When concluding the central controller ID setting mode, be sure to return the SW1 value to that of the Modbus slave address.

7 Test run check

■ Before starting test run

- Set the indoor unit central control address so that it does not match any other indoor unit addresses.
- Be sure to press the reset switch SW7 on the Modbus interface when the indoor unit central control address setting has been changed or added.

■ Test run

- (1) Check the communication status between Modbus interface and indoor unit or TCB-IFCG1TLE with LED5.
Check that the communication between Modbus interface and each indoor unit or TCB-IFCG1TLE connected is normally performed by selecting an indoor unit or TCB-IFCG1TLE using SW1 to SW3.

Confirming procedure:

- Set bit2 of SW3 to "ON" during normal operation.
- Set the central control address of the target indoor unit with SW1 and SW2. Set SW1 and SW2 according to the "Indoor unit central control address and SW1/SW2 setting" table below.
- Communication status is displayed by LED5.

Communication status with indoor unit	LED5	Remarks
Normal	Lighting	
Error	Blinking	Communication with the indoor unit was established previously, but is disabled currently.
Invalid indoor unit	Light off	Communication with the indoor unit has never been established.

- The protocol for communication with an indoor unit is displayed by LED4.

Protocol for communication with indoor unit	LED4	Note
In communication via Uh Line	On	When Modbus interface is performing communication with the relevant indoor unit via Uh Line.
In communication based on old communication protocol	Blinking	When Modbus interface is performing communication with the relevant indoor unit based on old communication protocol.

- (Example) Check the communication status of indoor unit with a central control address of 41.
Set bit2 of SW3 to "ON", SW2 to "2" and SW1 to "8".

Indoor unit or TCB-IFCG1TLE central control address and SW1/SW2 setting

Indoor unit central control address	SW2	SW1	Indoor unit central control address	SW2	SW1	Indoor unit central control address	SW2	SW1	Indoor unit central control address	SW2	SW1
1	0	0	17	1	0	33	2	0	49	3	0
2	0	1	18	1	1	34	2	1	50	3	1
3	0	2	19	1	2	35	2	2	51	3	2
4	0	3	20	1	3	36	2	3	52	3	3
5	0	4	21	1	4	37	2	4	53	3	4
6	0	5	22	1	5	38	2	5	54	3	5
7	0	6	23	1	6	39	2	6	55	3	6
8	0	7	24	1	7	40	2	7	56	3	7
9	0	8	25	1	8	41	2	8	57	3	8
10	0	9	26	1	9	42	2	9	58	3	9
11	0	A	27	1	A	43	2	A	59	3	A
12	0	B	28	1	B	44	2	B	60	3	B

Indoor unit central control address	SW2	SW1	Indoor unit central control address	SW2	SW1	Indoor unit central control address	SW2	SW1	Indoor unit central control address	SW2	SW1
13	0	C	29	1	C	45	2	C	61	3	C
14	0	D	30	1	D	46	2	D	62	3	D
15	0	E	31	1	E	47	2	E	63	3	E
16	0	F	32	1	F	48	2	F	64	3	F
65	4	0	81	5	0	97	6	0	113	7	0
66	4	1	82	5	1	98	6	1	114	7	1
67	4	2	83	5	2	99	6	2	115	7	2
68	4	3	84	5	3	100	6	3	116	7	3
69	4	4	85	5	4	101	6	4	117	7	4
70	4	5	86	5	5	102	6	5	118	7	5
71	4	6	87	5	6	103	6	6	119	7	6
72	4	7	88	5	7	104	6	7	120	7	7
73	4	8	89	5	8	105	6	8	121	7	8
74	4	9	90	5	9	106	6	9	122	7	9
75	4	A	91	5	A	107	6	A	123	7	A
76	4	B	92	5	B	108	6	B	124	7	B
77	4	C	93	5	C	109	6	C	125	7	C
78	4	D	94	5	D	110	6	D	126	7	D
79	4	E	95	5	E	111	6	E	127	7	E
80	4	F	96	5	F	112	6	F	128	7	F

(2) Check the communication status between Modbus Interface and outdoor unit with LED5.

Check that the communication between Modbus Interface and each outdoor unit connected is normally performed by selecting an outdoor unit using SW1 to SW3.

Confirming procedure:

- Set bit2 of SW3 to “ON” during normal operation.
- Set the line address of the target outdoor unit with SW1 and SW2.
Set SW1 and SW2 according to the table below, titled “Line address of outdoor unit and SW1/SW2 setting”.
- Communication status is displayed by LED5.

Communication status with outdoor unit	LED5	Remarks
Normal	Lighting	Modbus interface is in communication with the outdoor unit.
Error	Blinking	Communication with the outdoor unit was established previously, but is disabled currently.
Invalid outdoor unit	Light off	Communication with the outdoor unit has never been established.

- The protocol for communication with an outdoor unit is displayed by LED4.

Protocol for communication with outdoor unit	LED4	Note
In communication via Uh Line	On	When Modbus interface is performing communication with the relevant outdoor unit via Uh Line.
In communication based on old communication protocol	Blinking	When Modbus interface is performing communication with the relevant outdoor unit based on old communication protocol.

(Example) Check the communication status of outdoor unit with line address of 10.
Set bit1 of SW3 to “ON”, SW2 to “8” and SW1 to “9”.

Line address of outdoor unit and SW1/SW2 setting

Line address of outdoor unit	SW2	SW1	Line address of outdoor unit	SW2	SW1
1	8	0	17	9	0
2	8	1	18	9	1
3	8	2	19	9	2
4	8	3	20	9	3
5	8	4	21	9	4
6	8	5	22	9	5
7	8	6	23	9	6
8	8	7	24	9	7
9	8	8	25	9	8
10	8	9	26	9	9
11	8	A	27	9	A
12	8	B	28	9	B
13	8	C	29	9	C
14	8	D	30	9	D
15	8	E	31	9	E
16	8	F	32	9	F

NOTE

For air conditioner (multi type), the line addresses of outdoor unit 29 to 32 are not used.

(3) Perform the communication status checking between Modbus interface and Modbus Master.

Check that the communication with Modbus Master is normally performed.

When bit2 of SW3 is set to "OFF", the communication status with the Modbus Master is displayed by LED5.

Communication status with Modbus Master	LED5	Remarks
Normal reception	Lighting	Lights for one second
Error	Light off	A communication error occurred or no data has been received.

■ LED indication during normal operation

LED		Description
LED1	Power indicator	Lights while the power is on.
LED2	RS-485 communication status indicator	Blinks during RS-485 communication.
LED3	Uh Line communication status indicator	Blinks during Uh Line communication.
LED4	Uh Line communication error indicator	Lights temporarily when Uh Line is busy.
LED5	TEST indicator	Used in the test mode.

Manufacturer / Importer

Name of manufacturer (制造商)

Toshiba Carrier Corporation

东芝开利株式会社

Address, city, country (住址)

72-34 Horikawa-cho, Saiwai-ku, Kawasaki-shi, Kanagawa-ken

212-0013, JAPAN

神奈川県川崎市幸区堀川町 72 番地 34

Name of the Importer/Distributor in EU

Toshiba Carrier EUROPE S.A.S

Address, city, country

Route de Thil 01120 Montluel FRANCE

Name of the Importer/Distributor in UK

Toshiba Carrier UK Ltd

Address, city, country

Porsham Close, Belliver Industrial Estate,

PLYMOUTH, Devon, PL6 7DB. United Kingdom

在中国的进口商 / 分销商名称

东芝开利空调销售 (上海) 有限公司

地址, 城市, 国家

上海市西藏中路 268 号来福士广场办公楼 501 室

Klimanıza ilişkin daha ayrıntılı bilgiler için ürün tanıtım broşürlerine,
gerektiğinde Alarko Carrier Yetkili Satıcı ve Servislerine ulaşabilmek için 444 0 128 numaralı
Müşteri Danışma Hattımıza başvurabilirsiniz.

Toshiba Carrier Corporation

336 TADEHARA, FUJI-SHI, SHIZUOKA-KEN 416-8521 JAPAN